



*MODEL XAD-4-45-GL
EXTRUDED STATIONARY LOUVER
DRAINABLE BLADE. AMCA LICENSED.*



Standard Construction:

- Frame:** 4" x .081 (101 mm x 2.1 mm) extruded aluminum (6063-T5).
- Blades:** .081 (2.1 mm) extruded aluminum (6063-T5), approximately 4-1/2" (114 mm) on centers.
- Blade Angle:** 45°
- Screen:** Bird screen - 3/4" x .050 (19 mm x 1.27 mm) flattened expanded aluminum in a removable frame on interior of louver.
- Finish:** Mill aluminum.
- Minimum Size:** 12"w x 12"h (305 mm x 305 mm)

Options:

- Screens:** Insect screen - 18 x 16 mesh aluminum
1/2" x .063 (12.7 mm x 1.6 mm) aluminum
Other - _____
- Finish:** Prime Coat
Baked Enamel
Kynar
Clear Anodize - 204-R1 and 215-R1
Integral Color Anodize
Other - _____

Sill Extensions:

- Flange:** 1-1/2" (38 mm) (front or rear)
- Notes:** Louvers fabricated 1/4" (6.4 mm) under opening size unless otherwise noted.

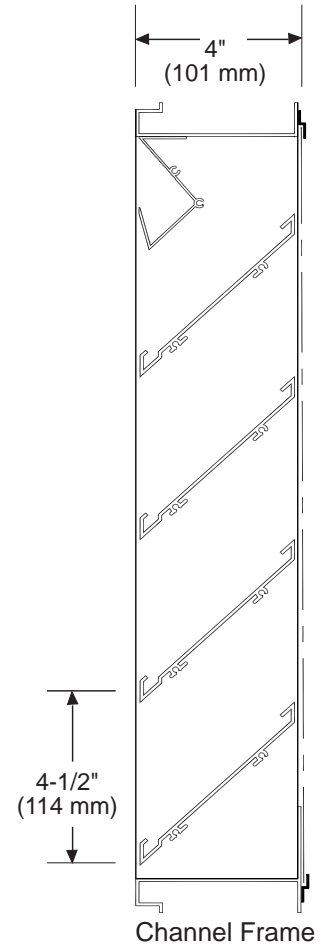

XAD-4-45-GL - 02-05

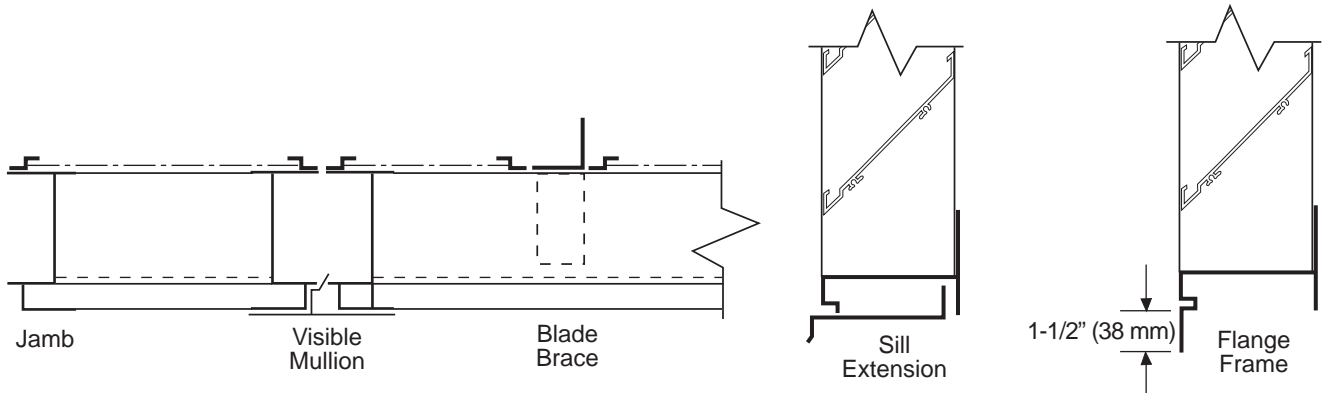

Specifications are correct at time of printing. However, as part of our 'continuous improvement program,' we reserve the right to make further improvements without notice.
© JULY, 2000 NCA Manufacturing

Project:	Contractor:
Location:	Address:
Architect:	P.O. Number:
Engineer:	Date:



*MODEL XAD-4-45-GL
EXTRUDED STATIONARY LOUVER
DRAINABLE BLADE. AMCA LICENSED.*

PERFORMANCE DATA

© JULY, 2000 NCA Manufacturing

Specifications

Furnish and install where shown model **XAD-4-45-GL** louver, manufactured by **NCA Manufacturing**. Louvers shall be the stationary **drainable** type with a frame depth of **4 inches**. Frames and blades shall be .081 inches thick 6063-T5 extruded aluminum alloy. Blades shall be located on a **45 degree** blade angle. Screens shall consist of 3/4" expanded aluminum, with an aluminum frame, mounted to the louver interior, and be removable for cleaning. Louvers shall be finished with Polyurethane Acrylic enamel, Kynar 500, Anodize or other finishes selected by the architect from NCA standard color charts.

XAD-4-45-GL Free Area in Sq. Ft.

Width – Inches

	12	18	24	30	36	42	48	54	60	66	72	78	84	90	96
12	0.33	0.55	0.77	0.98	1.20	1.42	1.64	1.86	2.08	2.30	2.51	2.73	2.95	3.17	3.39
18	0.60	1.00	1.40	1.79	2.19	2.59	2.99	3.39	3.79	4.19	4.58	4.98	5.38	5.78	6.18
24	0.76	1.27	1.77	2.28	2.79	3.29	3.80	4.31	4.81	5.32	5.83	6.33	6.84	7.35	7.85
30	1.03	1.71	2.40	3.08	3.77	4.45	5.14	5.83	6.51	7.20	7.88	8.57	9.25	9.94	10.62
36	1.30	2.16	3.03	3.89	4.76	5.62	6.49	7.36	8.22	9.09	9.95	10.82	11.68	12.55	13.41
42	1.46	2.43	3.41	4.38	5.35	6.33	7.30	8.27	9.25	10.22	11.19	12.17	13.14	14.11	15.09
48	1.73	2.88	4.03	5.18	6.34	7.49	8.64	9.79	10.94	12.10	13.25	14.40	15.55	16.70	17.86
54	2.00	3.33	4.66	5.99	7.33	8.66	9.99	11.32	12.65	13.99	15.32	16.65	17.98	19.31	20.65
60	2.16	3.60	5.04	6.48	7.92	9.36	10.80	12.24	13.68	15.12	16.56	18.00	19.44	20.88	22.32
66	2.43	4.05	5.67	7.28	8.90	10.52	12.14	13.76	15.38	17.00	18.61	20.23	21.85	23.47	25.09
72	2.70	4.50	6.30	8.09	9.89	11.69	13.49	15.29	17.09	18.89	20.68	22.48	24.28	26.08	27.88
78	2.86	4.77	6.67	8.58	10.49	12.39	14.30	16.21	18.11	20.02	21.93	23.83	25.74	27.65	29.55
84	3.13	5.21	7.30	9.38	11.47	13.55	15.64	17.73	19.81	21.90	23.98	26.07	28.15	30.24	32.32
90	3.40	5.66	7.93	10.19	12.46	14.72	16.99	19.26	21.52	23.79	26.05	28.32	30.58	32.85	35.11
96	3.56	5.93	8.31	10.68	13.05	15.43	17.80	20.17	22.55	24.92	27.29	29.67	32.04	34.41	36.79

Height – Inches

XAD-4-45-GL - 02-05

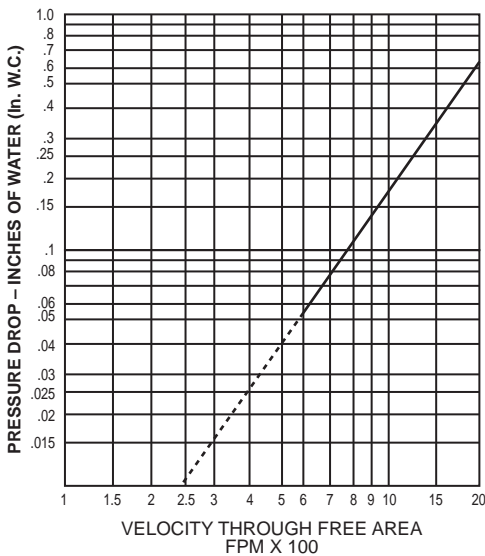

PRESSURE DROP INTAKE

Pressure Drop Data applies to test unit size 48" x 48" only.
Performance Data does not include the effects of birdscreen.

NCA Manufacturing, Inc. certifies that the Model XAD-4-45-GL louver shown herein is licensed to bear the AMCA seal. The ratings shown are based on tests and procedures performed in accordance with AMCA Publication 511 and comply with the requirements of the AMCA Certified Ratings program.

The AMCA Certified Seal applies to air performance ratings and water penetration ratings.

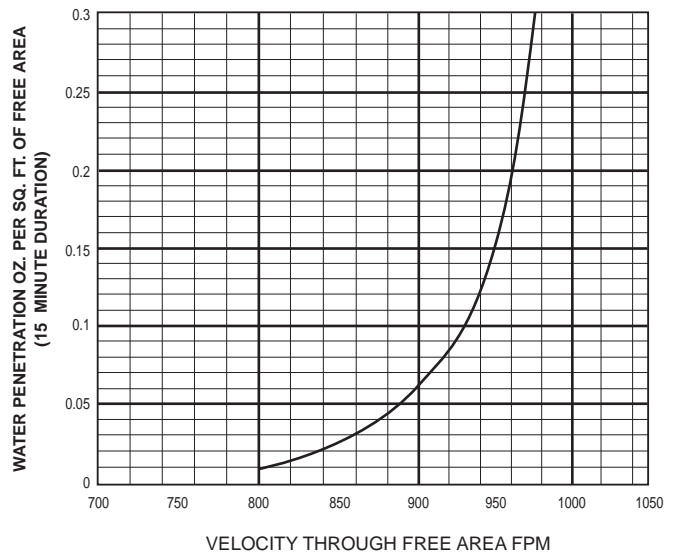

Water Penetration

Water Penetration Data applies to test unit size 48" x 48" only.
Beginning of Water Penetration is 803 FPM Free Area Velocity.
Performance shown is at standard air density 0.075 lbs./ft³.

© JULY, 2000 NCA Manufacturing