



CEILING DAMPER ROUND

Models:

- CD-RD: Round, butterfly-type (non-asbestos).
- CD-RD-A: Same as above with adjustable volume controller.



LISTED AND LABELLED BY:



DESIGNED AND TESTED IN ACCORDANCE WITH UL-555C AND ULC-S112.2. MEETS ALL NFPA-90A REQUIREMENTS FOR FIRE DAMPERS.

Standard Construction:

- Frame: 24 ga. galv. steel.
- Blades: 22 ga. galv. steel.
- Thermal Blanket: Non-asbestos, ceramic blanket.
- Spring: Corrosion resistant steel spring.
- Fusible Link: Replaceable 212°F standard. Others available.
- Finish: Mill.
- Sizes: 5" minimum (127 mm)
18" maximum (456 mm).
(For sizes 19" (482 mm) and 20" (508 mm) CFSR-2 will be supplied).
- UL/ULC Listing: 3-4 hours.

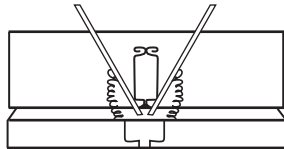
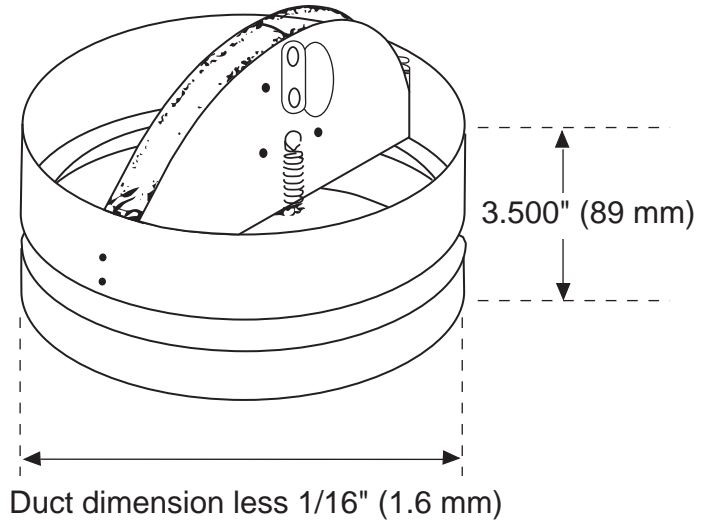

CD-RD-A
with Adjustable Volume Controller

CD-RD-A 09-06 (CD-RD-A)

SUGGESTED SPECIFICATION

Round ceiling damper's shall be Model CD-RD or CD-RD-A by NCA Manufacturing. Ceiling dampers shall bear the Underwriters' Laboratories label and be rated for both steel duct and flex duct installations. No external damper supports shall be required for ceiling dampers up to and including 18" (456 mm) diameter. Ceiling dampers shall be of the non-asbestos type and be furnished with a fusible link volume controller where shown (Model CD-RD-A).

Manufacturer's Recommendations

All moving parts of the damper must be inspected and cycled once the first year and at intervals not greater than every 4 years after or in accordance with the latest edition of NFPA 90A, 92A, local and national codes. In addition, the fuse link shall be removed and inspected for corrosion. Dry lubricants are recommended.

Specifications are correct at time of printing. However, as part of our 'continuous improvement program,' we reserve the right to make further improvements without notice.

© 2007 NCA Manufacturing

| | |
|------------|--------------|
| Project: | Contractor: |
| Location: | Address: |
| Architect: | P.O. Number: |
| Engineer: | Date: |