

## MODEL OBDA – OPPOSED BLADE DAMPER

1. ALUMINUM CONSTRUCTION
2. OPPOSED BLADE DAMPER
3. DOUBLE WALL BLADES SET IN U-CHANNEL FRAME
4. BLADES SET ON 1-1/2" CENTERS
5. SNAPS EASILY ON SELECTED US-AIRE GRILLES
6. SCREWDRIVER OPERATED
7. MILL (M) FINISH

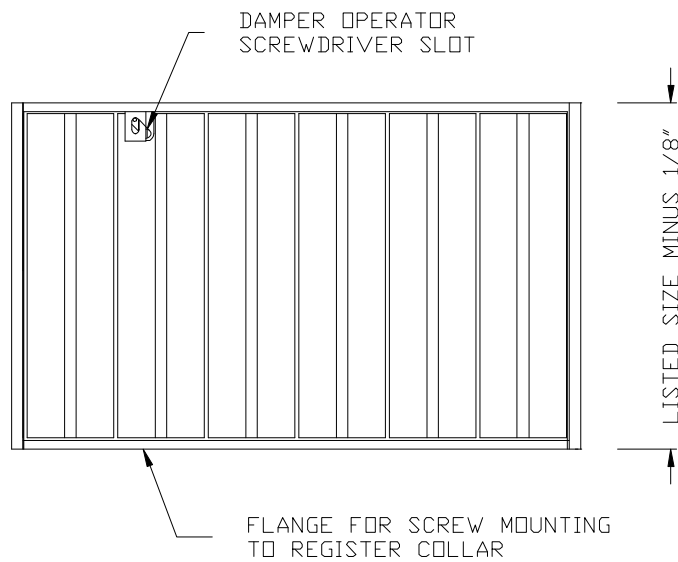

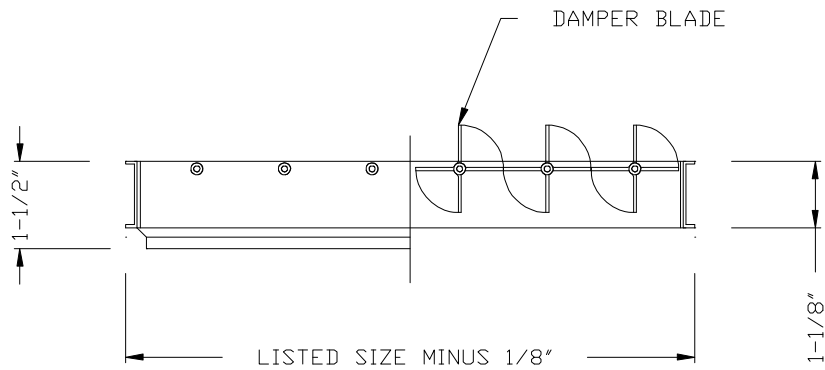

**MODEL OBDA**  
 OPPOSED BLADE DAMPER  
 ALUMINUM

**MODEL OBDA – OPPOSED BLADE DAMPER**

OBDA																						
Height	Width																					
	6"	8"	10"	12"	14"	16"	18"	20"	22"	24"	26"	28"	30"	32"	34"	36"	38"	40"	42"	44"	46"	48"
4"	X	X	X	X	X	X	X	X	X	X	X	X	X	X	X	X	X	X	X	X	X	X
5"	X	X	X	X	X	X	X	X	X	X	X	X	X	X	X	X	X	X	X	X	X	X
6"	X	X	X	X	X	X	X	X	X	X	X	X	X	X	X	X	X	X	X	X	X	X
8"		X	X	X	X	X	X	X	X	X	X	X	X	X	X	X	X	X	X	X	X	X
10"			X	X	X	X	X	X	X	X	X	X	X	X	X	X	X	X	X	X	X	X
12"				X	X	X	X	X	X	X	X	X	X	X	X	X	X	X	X	X	X	X
14"					X	X	X	X	X	X	X	X	X	X	X	X	X	X	X	X	X	X
16"						X	X	X	X	X	X	X	X	X	X	X	X	X	X	X	X	X
18"							X	X	X	X	X	X	X	X	X	X	X	X	X	X	X	X
20"								X	X	X	X	X	X	X	X	X	X	X	X	X	X	X
22"									X	X	X	X	X	X	X	X	X	X	X	X	X	X
24"										X	X	X	X	X	X	X	X	X	X	X	X	X
26"											X	X	X	X	X	X	X	X	X	X	X	X
28"												X	X	X	X	X	X	X	X	X	X	X
30"													X	X	X	X	X	X	X	X	X	X
32"														X	X	X	X	X	X	X	X	X
34"															X	X	X	X	X	X	X	X
36"																X	X	X	X	X	X	X
38"																	X	X	X	X	X	X
40"																		X	X	X	X	X
42"																			X	X	X	X
44"																				X	X	X
46"																					X	X
48"																						X